

ASNT6114A-KMC DC-32GHz 1-to-2 Analog Signal Splitter

- DC to 32GHz broadband linear signal splitter
- One differential CML-type input port and two phase-matched differential CML-type output ports
- Differential input linearity range up to 800mV p-p
- Differential gain of approximately 0dB
- Adjustable currents for bandwidth and peaking control
- Low jitter and limited temperature variation over industrial temperature range
- Single +3.3V or -3.3V power supply
- Power consumption: 760mW typical
- Fabricated in SiGe for high performance, yield, and reliability
- Custom CQFP 24-pin package

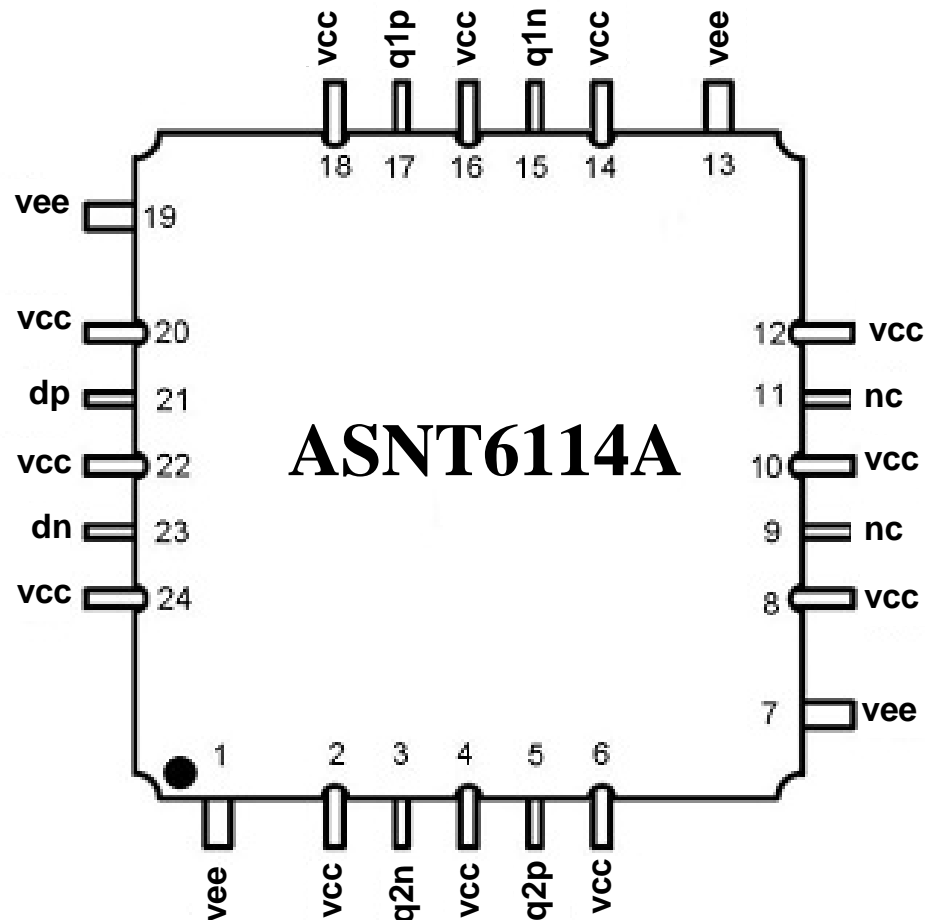

DESCRIPTION

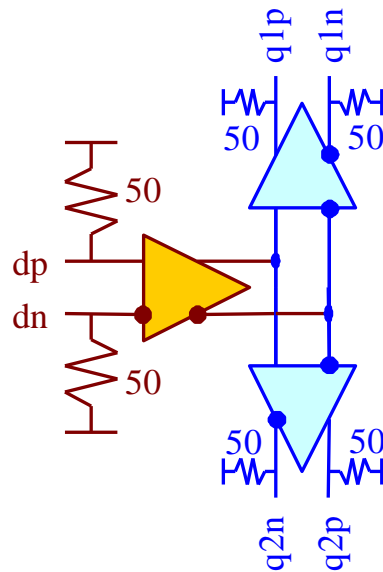

Fig. 1. Functional Block Diagram

The temperature stable ASNT6114A-KMC 1-to-2 analog signal splitter is intended for use in high-speed interleaved ADCs or similar systems. The IC shown in Fig. 1 can receive a broad-band analog signal at its differential input dp/dn and effectively distribute it to two separate phase matched differential outputs q1p/q1n, q2p/q2n with a nominal gain of 0dB. Typical S21 plot is shown in Fig. 2.

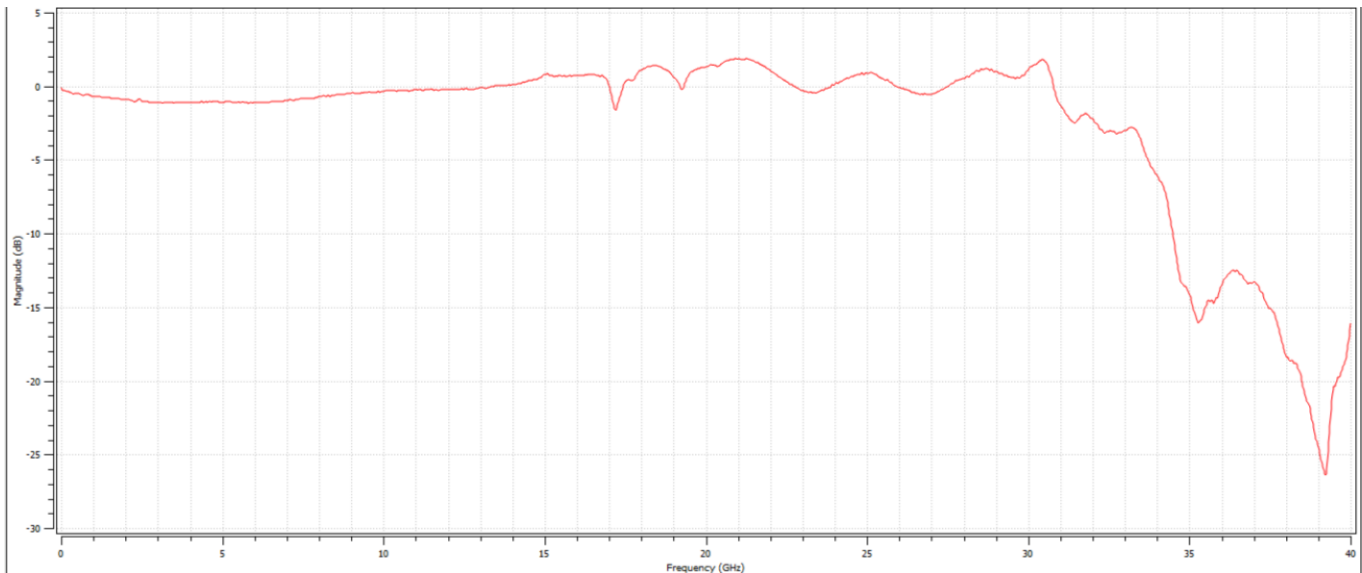

Fig. 2. Typical S21 Plot

The part's I/O's support the CML logic interface with on chip 50Ohms termination to VCC and may be used differentially, AC/DC coupled, single-ended, or in any combination (also see POWER SUPPLY CONFIGURATION). In the DC-coupling mode, the input signal's common mode voltage should comply



with the specifications shown in ELECTRICAL CHARACTERISTICS. In the AC-coupling mode, the input termination provides the required common mode voltage automatically.

POWER SUPPLY CONFIGURATION

The part can operate with either negative supply ($v_{cc} = 0.0V = \text{ground}$ and $v_{ee} = -3.3V$), or positive supply ($v_{cc} = +3.3V$ and $v_{ee} = 0.0V = \text{ground}$). In case of the positive supply, all I/Os need AC termination when connected to any devices with 50Ω termination to ground. Different PCB layouts will be needed for each different power supply combination.

All the characteristics detailed below assume $v_{cc} = 0.0V$ and $v_{ee} = -3.3V$.

ABSOLUTE MAXIMUM RATINGS

Caution: Exceeding the absolute maximum ratings shown in Table 1 may cause damage to this product and/or lead to reduced reliability. Functional performance is specified over the recommended operating conditions for power supply and temperature only. AC and DC device characteristics at or beyond the absolute maximum ratings are not assumed or implied. All min and max voltage limits are referenced to ground.

Table 1. Absolute Maximum Ratings

Parameter	Min	Max	Units
Supply Voltage (v_{ee})		-3.6	V
Power supply current		300	mA
Input Voltage	$v_{cc}-1.6$	$v_{cc}-0.2$	V
RF Input Voltage Swing (SE)		1.4	V
Case Temperature	-40	+90	°C
Storage Temperature	-40	+100	°C
Operational Humidity	10	98	%
Storage Humidity	10	98	%

TERMINAL FUNCTION

TERMINAL			DESCRIPTION
Name	No.	Type	
dp	21	CML input	Differential high speed data inputs with internal SE 50Ω termination to VCC
dn	23		
q1p	17	CML output	Differential high speed data outputs with internal SE 50Ω termination to VCC. Require external SE 50Ω termination to VCC
q1n	15		
q2p	5	CML output	
q2n	3		
Supply and Termination Voltages			
Name	Description		Pin Number
vcc	Positive power supply (+3.3V or 0)		2, 4, 6, 8, 10, 12, 14, 16, 18, 20, 22, 24
vee	Negative power supply (0V or -3.3V)		1, 7, 13, 19
nc	Not connected pins		9, 11



ELECTRICAL CHARACTERISTICS

PARAMETER	MIN	TYP	MAX	UNIT	COMMENTS
General Parameters					
vee	-3.1	-3.3	-3.5	V	±6%
vcc		0.0		V	External ground
I _{vee}	180	230	250	mA	
Power consumption	560	760	825	mW	
Junction temperature	-25	50	125	°C	
Input Analog (dp/dn)					
Bandwidth	DC		32	GHz	-3dB
Common mode voltage level		vcc		V	
Voltage swing, pk-pk	0		400	mV	Single ended, unused input not connected or AC terminated
	0		800	mV	Differential
Input Noise Density		1.5		nV/sqrt(Hz)	
S11		-35		dB	at 3GHz
		-16		dB	at 10GHz
		-11		dB	at 20GHz
		-9		dB	at 25GHz
Output Analog (q1p/q1n, q2p/q2n)					
Common mode level		vcc-0.55		V	With external 50Ohms DC termination
Small Signal Differential Gain		0		dB	up to 10GHz
Output referred 1dB Compression Point		1		dBm	Single-Ended, 20GHz
THD		0.3		%	at 1GHz
THD		0.4		%	at 10GHz
THD		0.9		%	at 25GHz
THD		3.5		%	at 35GHz

PACKAGE INFORMATION

The die is housed in a custom 24-pin CQFP package shown in Fig. 3. The package's leads will be trimmed to a length of 1.0mm. After trimming, the package's leads will be further processed as follows:

1. The lead's gold plating will be removed per the following sections of J-STD-001D:
 - 3.9.1 Solderability
 - 3.2.2 Solder Purity Maintenance
 - 3.9.2 Solderability Maintenance
 - 3.9.3 Gold Removal
2. The leads will be tinned with Sn63Pb37 solder



The package provides a center heat slug located on its back side to be used for heat dissipation. ADSANTEC recommends for this section be soldered to the VCC plain, which is ground for a negative supply, or power for a positive supply.

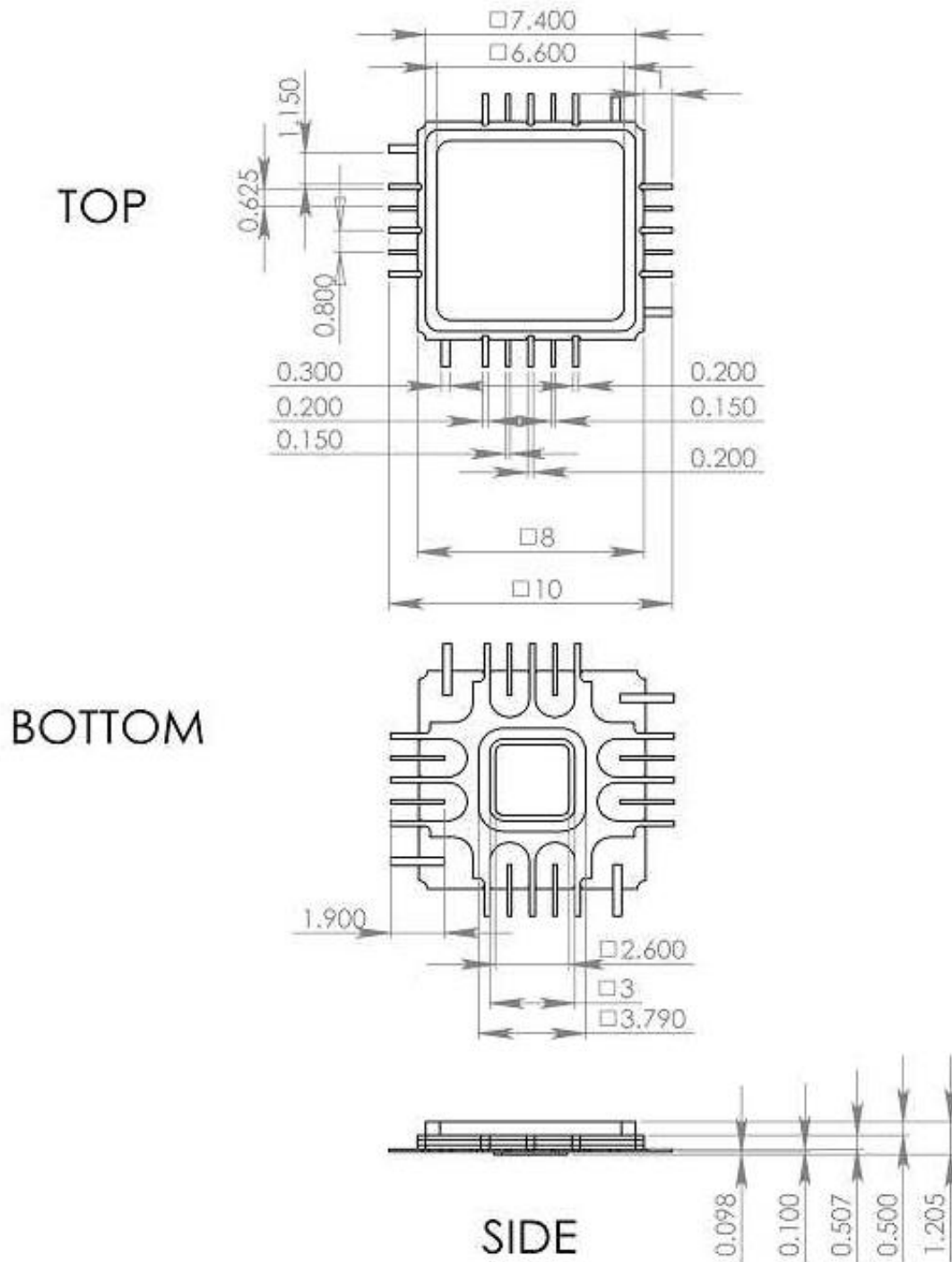

Fig. 3. CQFP 24-Pin Package Drawing (All Dimensions in mm)



The part's identification label is ASNT6114A-KMC. The first 9 characters of the name before the dash identify the bare die including general circuit family, fabrication technology, specific circuit type, and part version while the 3 digits after the underscore represent the package's manufacturer, type, and pin out count.

This device complies with Commission Delegated Directive (EU) 2015/863 of 4 June 2015 amending Annex II to Directive 2011/65/EU of the European Parliament and of the Council as regards the list of restricted substances (Text with EEA relevance) on the restriction of the use of certain hazardous substances in electrical and electronics equipment (RoHS Directive) in accordance with the definitions set forth in the directives for all ten substances.

REVISION HISTORY

Revision	Date	Changes
1.5.2	11-2024	Updated Package Information
1.4.2	12-2020	Updated Absolute Maximum Ratings section
1.3.2	12-2020	Updated Absolute Maximum for RF input swing
1.2.2	11-2020	Updated Package Information
1.1.2	05-2020	Updated Package Information
1.0.2	10-2019	First release