

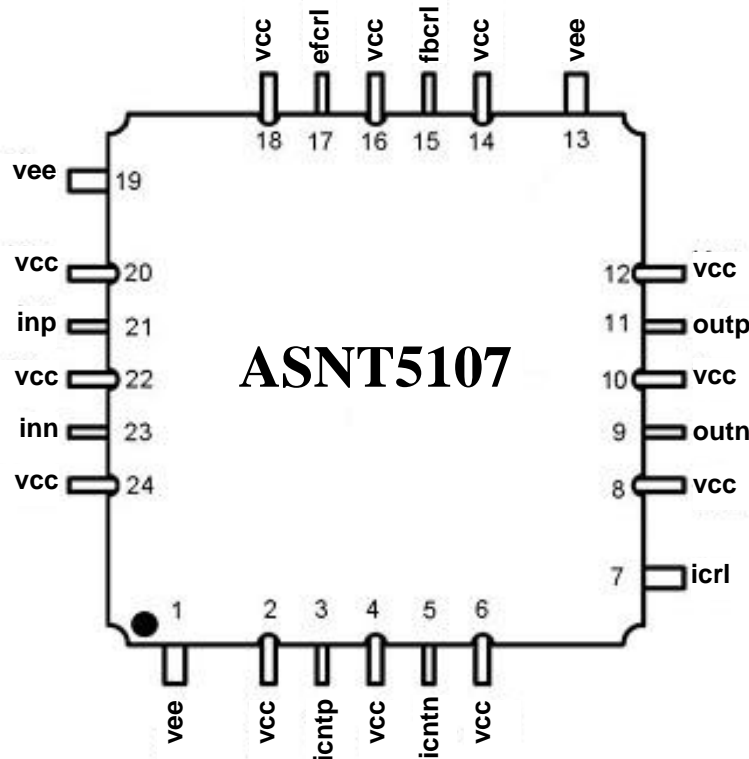

ASNT5107-KMC DC-32Gbps/26GHz Signal Phase Shifter

- Broadband tunable data/clock phase shifter
- Manual control of power consumption / operational speed
- 1GHz of bandwidth for the phase adjustment tuning port
- Automatic temperature and process corner delay compensation with manual override
- Duty cycle distortion compensation with adjustable gain
- Manual internal peaking control
- Fully differential CML input interface
- Fully differential CML output interface
- Single +3.3V or -3.3V power supply
- Fabricated in SiGe for high performance, yield, and reliability
- Custom CQFP 24-pin package



DESCRIPTION

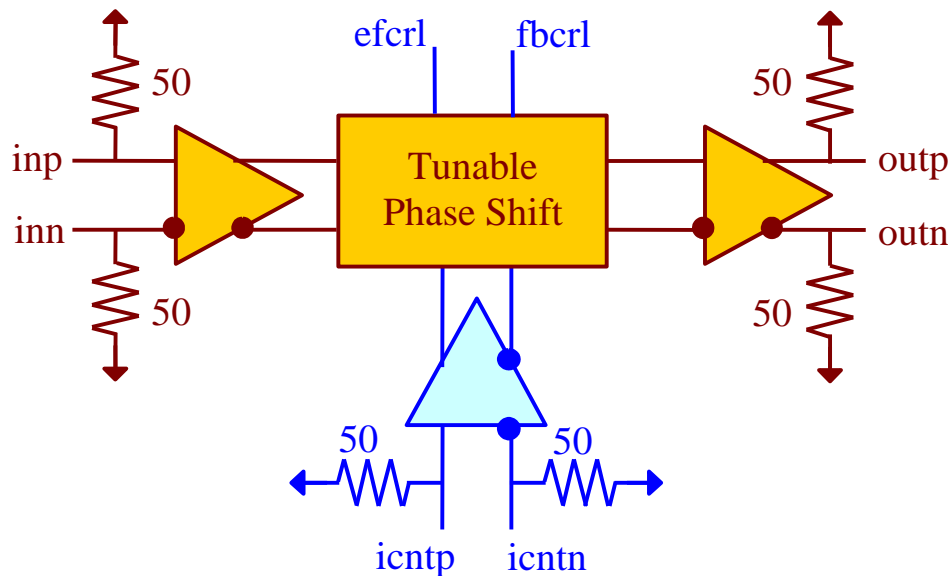

Fig. 1. Functional Block Diagram

ASNT5107-KMC is a data/clock variable delay line with an advanced control system fabricated in SiGe technology. The IC shown in Fig. 1 provides an adjustable delay of its differential output signal **outp/outn** in relation to its broadband input signal **inp/inn**. The delay is controlled through a wide-band differential tuning port **icntp/icntn**. The chip incorporates an automatic common-mode offset cancellation circuit that operates with either clock signals or data signals with balanced patterns. In case of non-balanced data patterns, the circuit should be disabled through the control port **fbcrl**. The single-ended control port **efcrl** can be used to manipulate internal peaking in the delay block in order to adjust the part's frequency response and thus improve output eye diagrams for various data rates and operating conditions.

The part's I/Os support the CML logic interface with on chip *50 Ohms* termination to **VCC** and may be used differentially, AC/DC coupled, single-ended, or in any combination (see also POWER SUPPLY CONFIGURATION). In the DC-coupling mode, the input signal's common mode voltage should comply with the specifications shown in ELECTRICAL CHARACTERISTICS. In the AC-coupling mode, the input termination provides the required common mode voltage automatically. The differential DC signaling mode is recommended for optimal performance.

The part's power consumption can be adjusted between its minimum (default), and maximum values using a single-ended analog control port **icrl**. It should be noted that higher power leads to higher operational speed of the part.

Due to an extremely low jitter, the part is suitable for use in high-speed measurement / test equipment.

Delay Control Port

The delay is controlled through a wide-band differential tuning port **icntp/icntn**. This part's delay control system was designed to minimize output jitter and increase the control function linearity. To achieve the goals, the control system is split so that each delay stage has its own control buffer. Only three stages

operate in interpolation mode at any delay position, and all the other stages are fully switched either to the short path or to the long path.

Feedback Gain Control Port

This part has two duty cycle correction feedback loops. In case of feedback malfunction, currents inside feedback amplifiers can be manually adjusted or completely shut down through a single-ended tuning port `fbcr1`. The simulated dependence of feedback reference current on the control voltage is shown in Fig. 2.

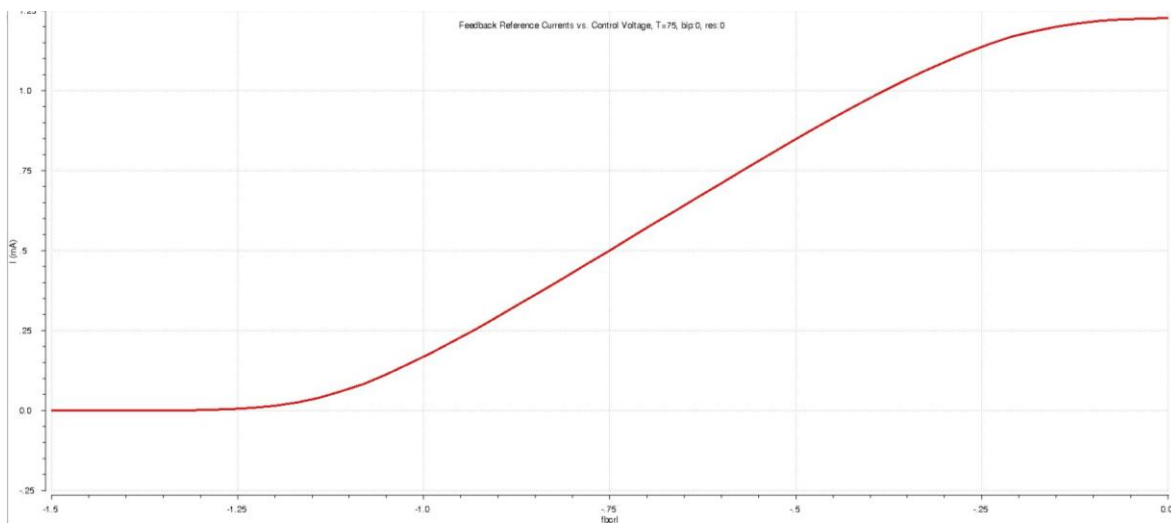

Fig. 2 Simulated Internal Feedback Current vs. Control Voltage

Higher feedback amplifier currents result in higher feedback gain and lower stability. If the port is left not connected, it defaults to an internal level of $V_{CC}-0.66V$, the feedback current is half its maximum value and the phase shifter is in normal operating mode.

Internal Peaking Control Port

Depending on the data rate and operational conditions, the part's output eye diagram may get distorted because of jitter caused by parasitic internal peaking. Internal peaking can be adjusted by varying currents of internal emitter followers through a single-ended port `efcr1`. The simulated dependence of reference current of internal emitter followers on the control voltage is shown in Fig. 3. If this port is left not connected, it defaults to an internal level of $V_{CC}-0.66V$ and, emitter follower currents are half of their maximum values and the circuit is in normal operating mode.

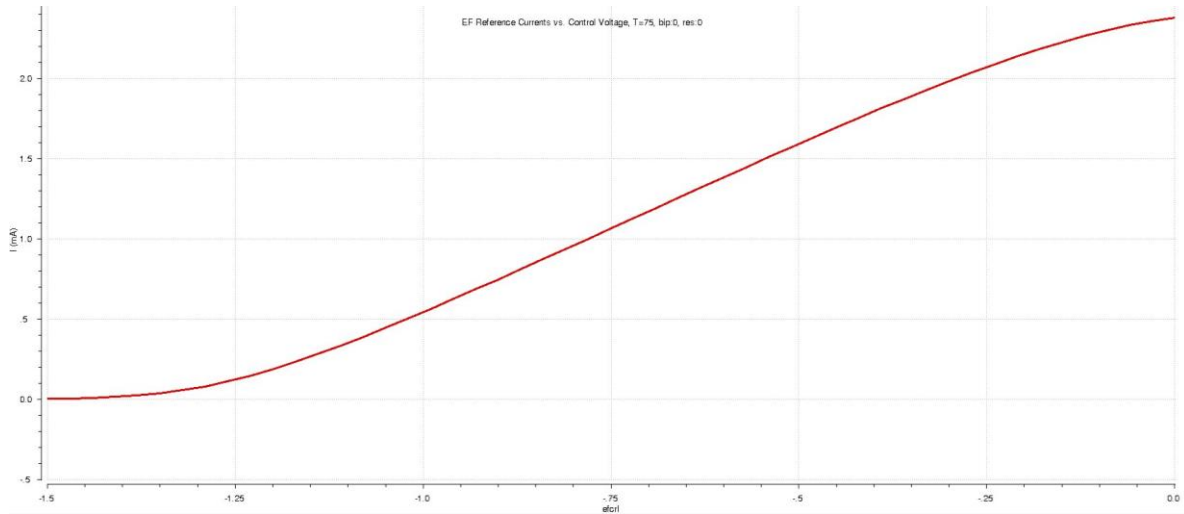

Fig. 3. Simulated Internal EF Reference Current vs. Control Voltage

POWER SUPPLY CONFIGURATION

The part can operate with either a negative supply ($v_{cc} = 0.0V = \text{ground}$), or a positive supply ($v_{ee} = 0.0V = \text{ground}$). In case of a positive supply, all I/Os need AC termination when connected to any devices with 50Ω termination to ground. Different PCB layouts will be needed for each different power supply combination.

The part's power consumption can be adjusted between its minimum and maximum values using a single-ended analog control port $icrl$. Higher voltages at the control input correspond to higher power consumption. With the non-connected control port, the part defaults to minimum power consumption. It should be noted that higher power consumption leads to higher operational speed of the part as detailed in ELECTRICAL CHARACTERISTICS.

All the characteristics detailed below assume $v_{cc} = 0.0V$.



ABSOLUTE MAXIMUM RATINGS

Caution: Exceeding the absolute maximum ratings shown in Table 1 may cause damage to this product and/or lead to reduced reliability. Functional performance is specified over the recommended operating conditions for power supply and temperature only. AC and DC device characteristics at or beyond the absolute maximum ratings are not assumed or implied. All min and max voltage limits are referenced to ground (assumed vcc).

Table 1. Absolute Maximum Ratings.

Parameter	Min	Max	Units
Supply Voltage (vee)		-3.6	V
Power supply current		400	mA
RF Input Voltage Swing (SE)		1.0	V
Case Temperature		+90	°C
Storage Temperature	-40	+100	°C
Operational Humidity	10	98	%
Storage Humidity	10	98	%

TERMINAL FUNCTIONS

TERMINAL			DESCRIPTION
Name	No.	Type	
High-Speed I/Os			
inp	21	CML input	Differential high-speed signal inputs with internal SE 50Ohms termination to vcc
inn	23		
icntp	3	input	Differential control input with internal SE 50Ohms terminations to vcc
icntn	5	input	
icrl	7	input	SE DC analog control input with internal 11.5KOhms termination to vee
fbcr1	15	input	SE DC control input terminated to internal resistive divider between vee and vcc
efcr1	17	input	
outp	11	CML output	Differential high-speed signal outputs with internal SE 50Ohms termination to vcc. Require external SE 50Ohms termination to vcc
outn	9		
Supply And Termination Voltages			
Name	Description		Pin Number
vcc	Positive power supply (+3.3V or 0)		2, 4, 6, 8, 10, 12, 14, 16, 18, 20, 22, 24
vee	Negative power supply (0V or -3.3V)		1, 13, 19



ELECTRICAL CHARACTERISTICS

PARAMETER	MIN	TYP	MAX	UNIT	COMMENTS
General Parameters					
vee	-3.1	-3.3	-3.5	V	±6%
vcc		0.0		V	External ground
I _{vee}	190		350	mA	Adjustable
Power consumption	630		1150	mW	Adjustable
Junction temperature	-25	50	125	°C	
HS Input Data/Clock (inp/inn)					
Data Rate	DC		32	Gbps	
Frequency	DC		20	GHz	At minimum power consumption
	DC		26	GHz	At maximum power consumption
Swing	0.05		1.0	V	Differential or SE, p-p
CM Voltage Level	vcc-0.8		vcc	V	Must match for both inputs
HS Output Data/Clock (outp/outn)					
Data Rate	DC		32	Gbps	
Frequency	DC		20	GHz	At minimum power consumption
	DC		26	GHz	At maximum power consumption
Logic "1" level		vcc		V	
Logic "0" level		vcc-0.44		V	With external 50Ohms DC termination.
Rise/Fall times	9		11	ps	20%-80%
Output Jitter		1.7		ps	For PRBS input, peak-to-peak
Duty cycle	45	50	55	%	For clock signal
Output-to-Input Delay					
Phase shift	0		110	ps	For the full range of phadj control signal
Phase shift stability	-6		6	ps	0-125°C junction temperature
Absolute delay stability	-15		15	ps	0-125°C junction temperature
Tuning port (icntp/icntn)					
Bandwidth	DC		1000	MHz	
Control voltage range	vcc-1000		vcc	mV	Default voltage is vcc
Tuning port (icrl)					
Control voltage range	vee		vcc	mV	Default voltage is vee
Tuning port (fbcrl)					
Control voltage range	vcc-1300		vcc	mV	Default voltage is vcc-0.66V
Tuning port (efcrl)					
Control voltage range	vcc-1300		vcc	mV	Default voltage is vcc-0.66V

PACKAGE INFORMATION

The die is housed in a custom 24-pin CQFP package shown in Fig. 4. The package's leads will be trimmed to a length of 1.0mm. After trimming, the package's leads will be further processed as follows:

1. The lead's gold plating will be removed per the following sections of J-STD-001D:
 - 3.9.1 Solderability
 - 3.2.2 Solder Purity Maintenance
 - 3.9.2 Solderability Maintenance
 - 3.9.3 Gold Removal
2. The leads will be tinned with Sn63Pb37 solder

The package provides a center heat slug located on its back side to be used for heat dissipation. ADSANTEC recommends for this section be soldered to the VCC plain, which is ground for a negative supply, or power for a positive supply.

The part's identification label is ASNT5107-KMC. The first 8 characters of the name before the dash identify the bare die including general circuit family, fabrication technology, specific circuit type, and part version while the 3 characters after the dash represent the package's manufacturer, type, and pin out count.

This device complies with Commission Delegated Directive (EU) 2015/863 of 4 June 2015 amending Annex II to Directive 2011/65/EU of the European Parliament and of the Council as regards the list of restricted substances (Text with EEA relevance) on the restriction of the use of certain hazardous substances in electrical and electronics equipment (RoHS Directive) in accordance with the definitions set forth in the directives for all ten substances.

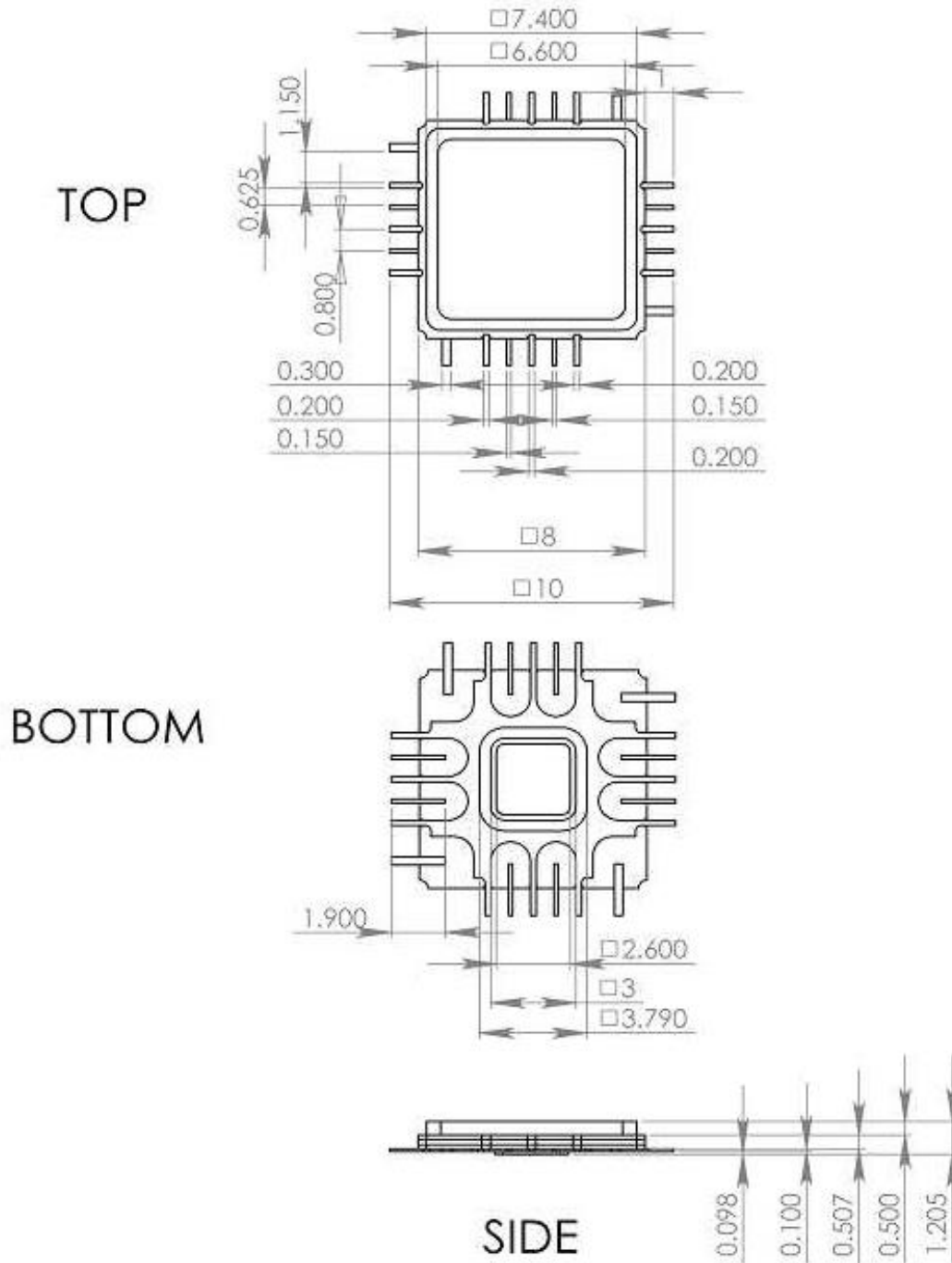

Fig. 4. CQFP 24-Pin Package Drawing (All Dimensions in mm)



REVISION HISTORY

Revision	Date	Changes
1.1.2	10-2024	Updated Package Information
1.0.2	01-2020	Corrected current and power consumption
0.0.2	09-2019	Updated Letterhead
0.0.1	09-2019	Preliminary release