

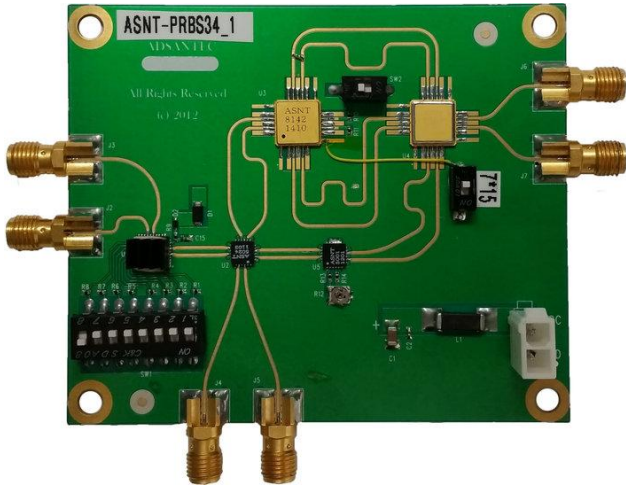

ASNT_PRBS34_1 8Gbps-34Gbps PRBS7/PRBS15 Generator with Sync Output



- Broadband frequency range from 8Gbps – 34Gbps
- On board data rate multiplexer to reduce the input clock frequency rate
- Adjustable phase shift for multiplexer clock input
- 1-256 divide sync output
- Differential inputs and outputs
- Minimal insertion jitter
- Fast rise and fall times
- 50% duty cycle sync output on all divide ratios
- Single +3.3V supply

Fig. 1. ASNT_PRBS34_1 evaluation board

DESCRIPTION

The ASNT_PRBS34_1 is a broadband 2^7-1 or $2^{15}-1$ PRBS generator intended for test, prototyping, microwave, and communication applications. A single-ended, or differential clock from 4GHz to 17GHz can be used. A differential Sync Output divides the input clock from 1 to 256 allowing a PRBS7 pattern view on an oscilloscope by using a divide ratio of 127, or 254. The PRBS7/PRBS15 data output is multiplexed to double the input data rate, giving a maximum output data rate of 34Gbps. An on-board trim potentiometer allows to phase adjust the multiplexer clock input for all input clock frequencies in a specified range to ensure the best output is achieved. An on-board PRBS reset switch presets the generator to avoid the all zero state lock-up.

The ASNT_PRBS34_1 board contains six Emerson SMA connectors MFG PN: 142-0761-881, 50Ohms transmission lines to the device, and power supply decoupling networks on the evaluation board. Power is supplied through a two-pin MOLEX connector P/N: 39-28-1023.



FUNCTIONAL BLOCK DIAGRAM

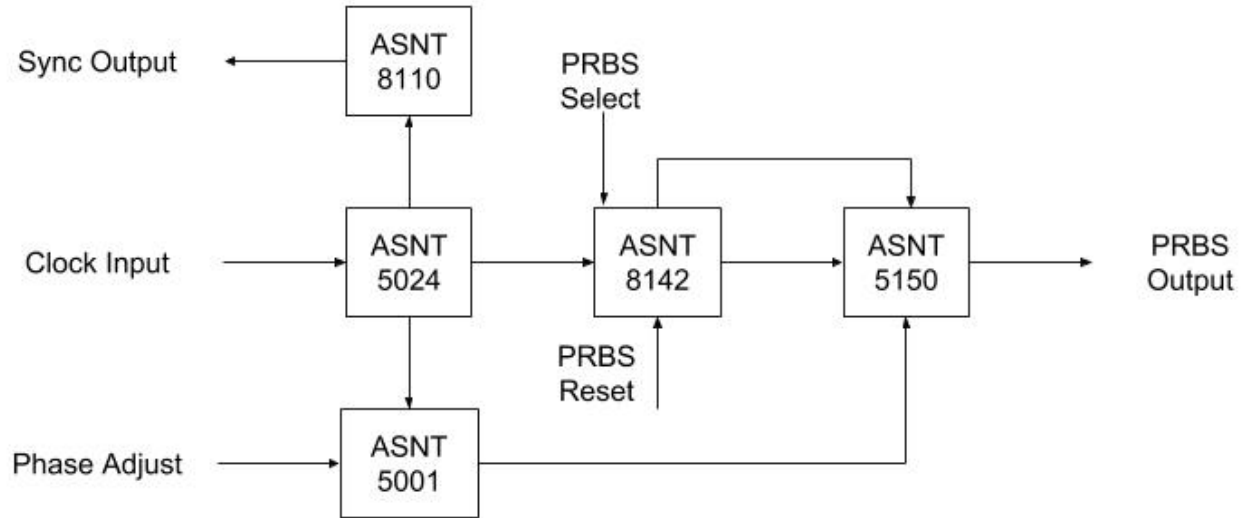

Fig. 2. Functional Block Diagram

TERMINAL FUNCTIONS

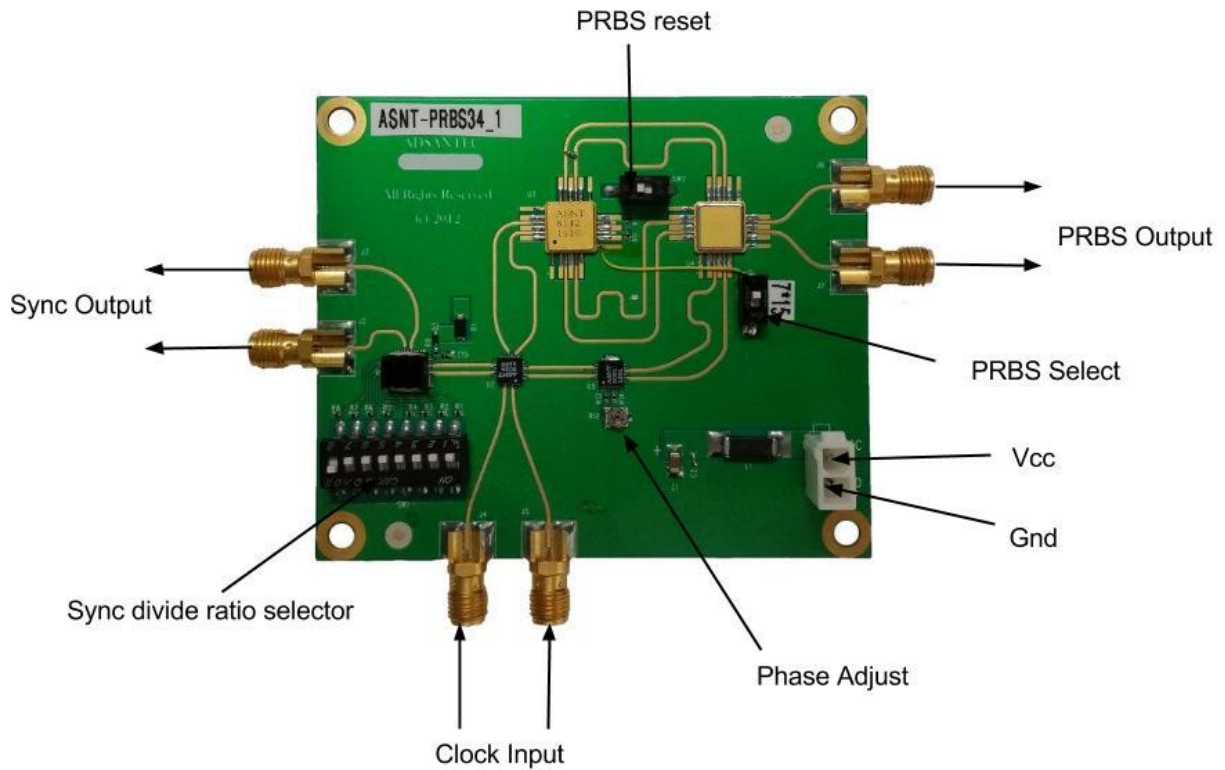

Figure 3. Terminal functions diagram

PRBS Select

Move the switch to the ON position for PRBS15 data. Move the switch to the OFF position for PRBS7 data output. The PRBS Reset may need to be toggled to the ON position then OFF before a PRBS pattern is observed on the data output.

Sync Output

The Sync Output can be configured to output any divide ratio from 1 to 256 of the clock input. It contains eight switches that represent 8 bits. The LSB starts at SW8, and the MSB ends at SW1. The binary value of zero gives a decimal n value of 256. Increasing binary values increases the decimal value n as shown in Table 1.

Table 1. Divide ratio

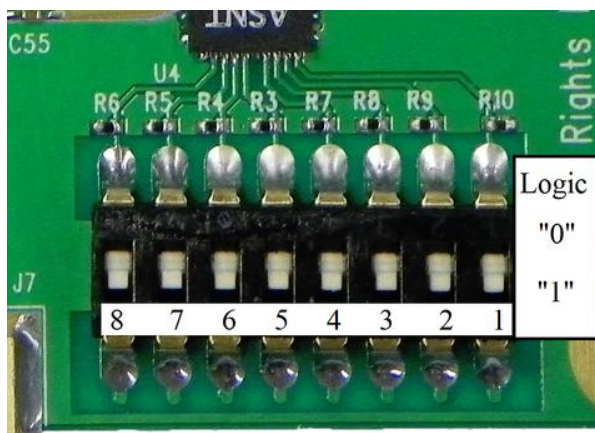

DIP SW #	n Divide Ratio	
8 7 6 5 4 3 2 1		
1 0 0 0 0 0 0 0	1	
0 1 0 0 0 0 0 0	2	
0 0 0 0 1 0 0 0	16	Eye diagram
.		
1 1 1 1 1 1 1 0	127	pattern
0 1 1 1 1 1 1 1	254	pattern
0 0 0 0 0 0 0 0	256	

Fig. 4. DIP switch settings

OPERATION

1. Measure 50Ohms on all SMA connectors referenced to vcc.
2. Set the PRBS Reset switch to the OFF position.
3. Set the power supply to 0.0V and current limit it to 1.9A.
4. Connect the power supply to the board, and slowly increase it to +3.3V.
5. Apply an AC coupled single-ended, or differential clock signal to the Clock Input.
(NOTE: If using a single-ended input only, apply an AC coupled 50Ohms termination to the unused input.)
6. Connect the PRBS Output to a 50Ohms terminated AC coupled oscilloscope single-ended, or differentially.
(NOTE: If using a single-ended output only, apply an AC coupled 50Ohms termination to the unused output.)
7. Connect the Sync Output AC coupled to trigger single-ended, or differentially.



(NOTE: If using a single-ended output only, apply an AC coupled 50Ohms termination to the unused output.)

- Set the PRBS Reset switch to the ON position then to the OFF position. Set the PRBS Select switch to the ON position to select PRBS15, or to the OFF position to select PRBS7.
- Use a divide-by-127 for the Sync Output to view the PRBS7 pattern on the oscilloscope.
- Scroll/Delay the 127 bit PRBS7 pattern on the oscilloscope until you observe a sequence of data close to 7 one's followed by 6 zero's. You may find a pattern shown below in **Figure 5**, which is incorrect.

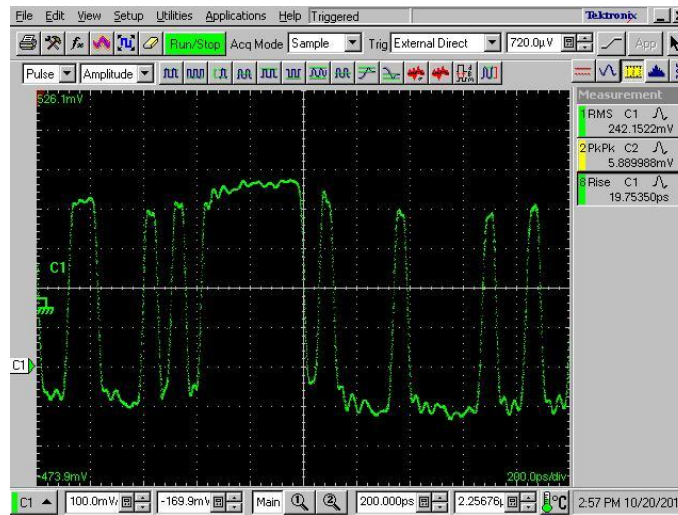

Figure 5. Incorrect PRBS7 pattern

- Adjust the Phase Adjust potentiometer in order to get the correct PRBS7 pattern as shown in **Figure 6**.

(NOTE: If the clock input rate is changed, repeat steps 8 and 11.)

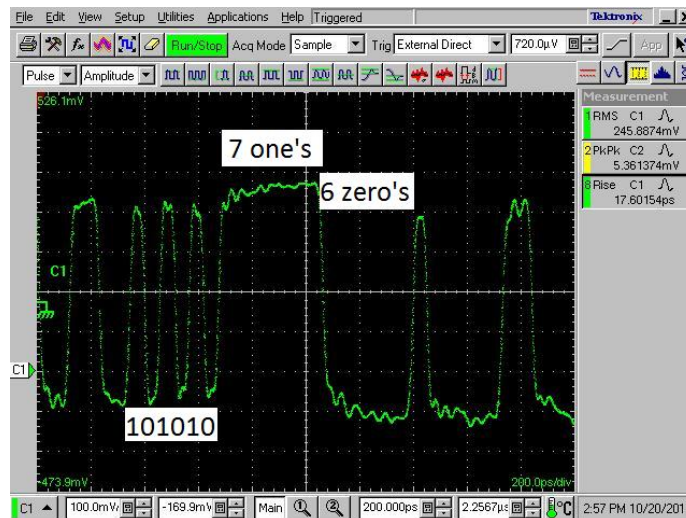

Figure 6. Correct PRBS7 pattern



12. **Figure 7** below provides a diagram with an example of how this board can be connected. (**NOTE:** The connections described below only represent one way of interfacing to the evaluation board. While the use of DC blocks will be required on the depicted outputs, there are many ways of connecting the board depending on the use case involved.)

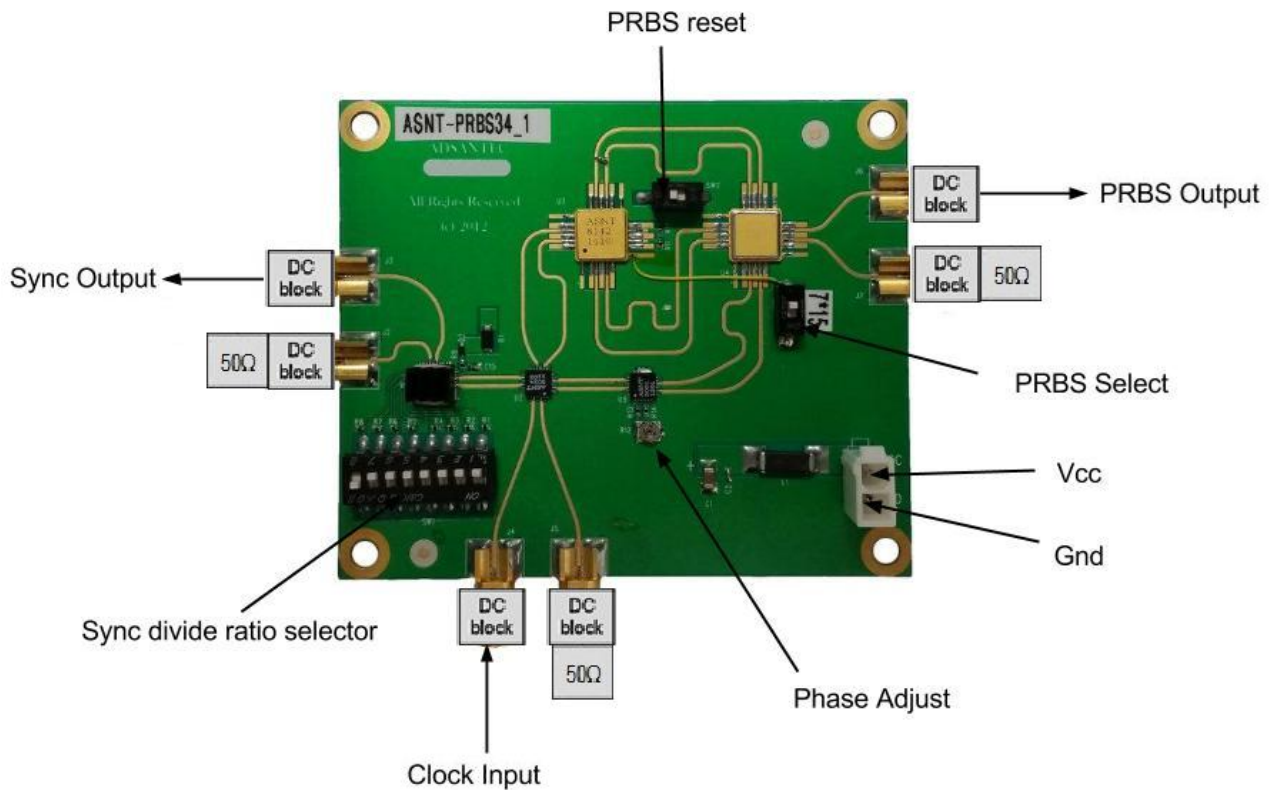

Fig. 7. Recommended Board Configuration Diagram



MEASURED RESULTS

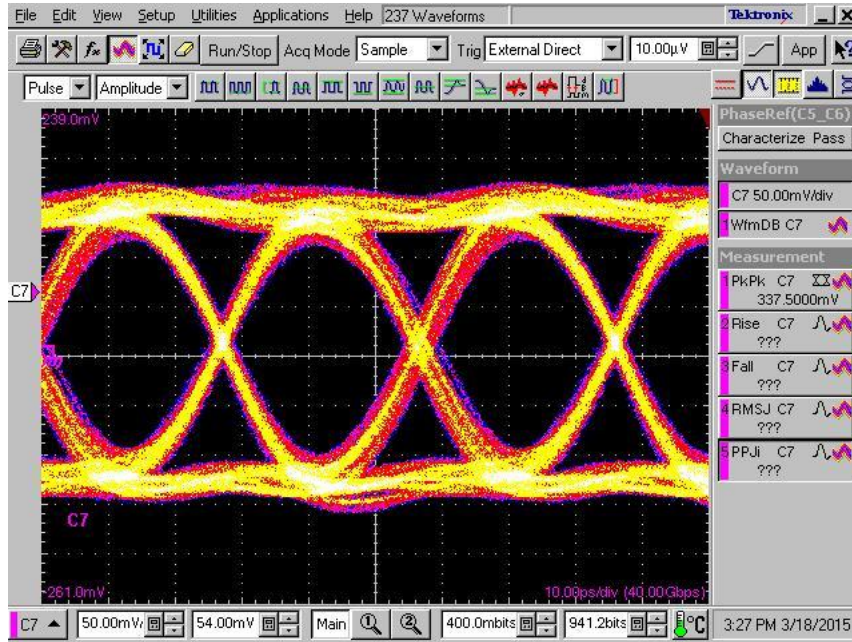

Fig. 8. 34Gbps eye diagram

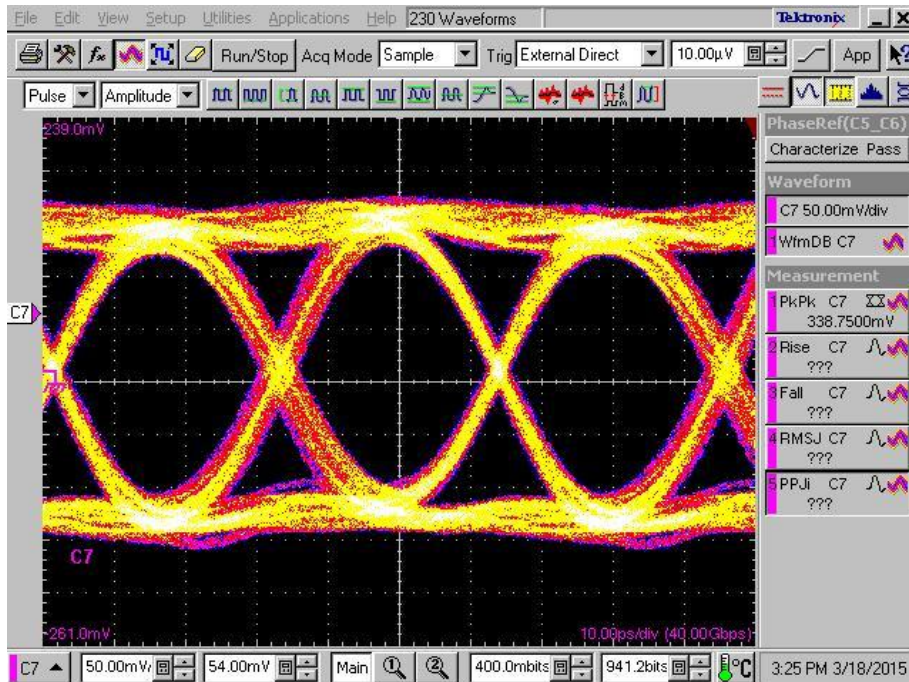

Fig. 9. 32Gbps eye diagram

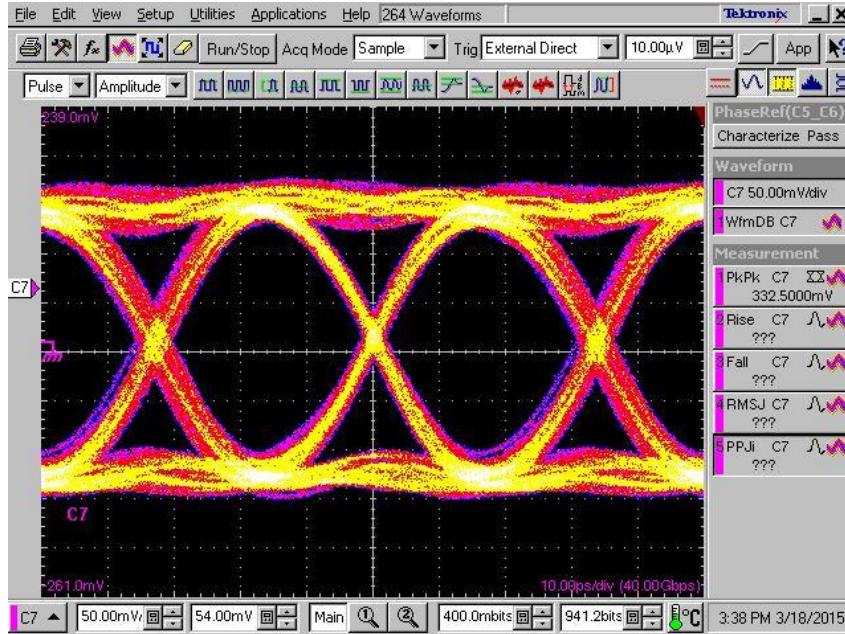

Fig. 10. 30Gbps eye diagram

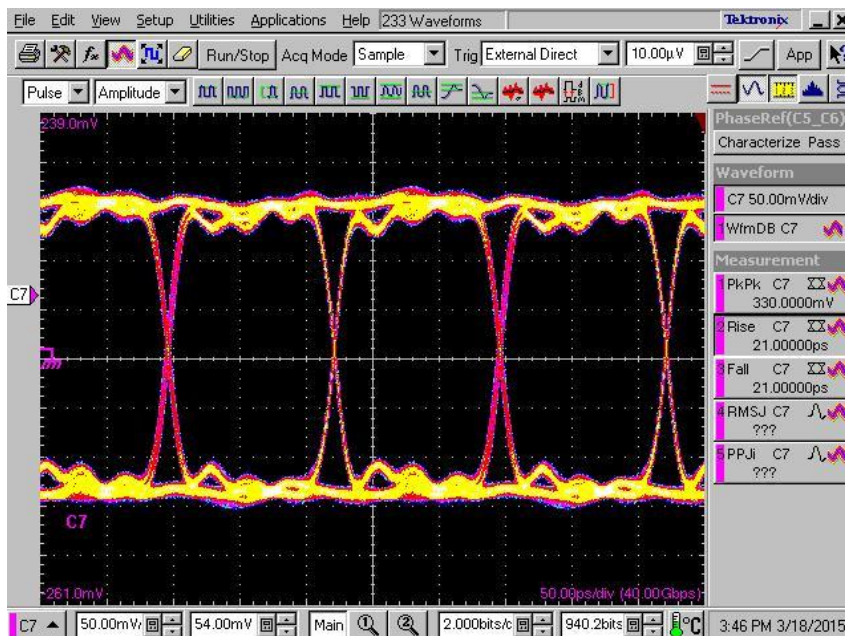

Fig. 11. 8Gbps eye diagram



ELECTRICAL CHARACTERISTICS

Parameter	Min	Typ	Max	Unit	Comments
vee		0		V	External ground
vcc	3.1	3.3	3.5	V	
Ivcc	1.4	1.75	2.08	A	
Power		5.6		W	
Operating Temperature	-25	50	85	°C	
Clock Input					
Frequency	4		17	GHz	
Single-Ended Swing	50	400	1000	mV	Peak-to-Peak
Common mode level	vcc -0.8	vcc -0.2	vcc	V	
Duty Cycle	40%	50%	60%		Range of input tolerance
Sync Output					
Frequency	0.007		17	GHz	
Single-Ended Swing	570	600	630	mV	Peak-to-Peak
Common-Mode Level	vcc - (Single-Ended Swing)/2				
Rise/Fall Times	15	17	19	ps	20% to 80%
Duty Cycle	45%	50%	55%		For clock signal
PRBS Output					
Data rate	8		34	Gbps	
Single-Ended Voltage Level		330		mV	Peak-to-Peak
Common Mode Level	vcc - (Single-Ended Swing)/2			V	
Duty Cycle	40%	50%	60%		
Rise/Fall Time		21		ps	20% to 80%



BOARD DIMENSIONS

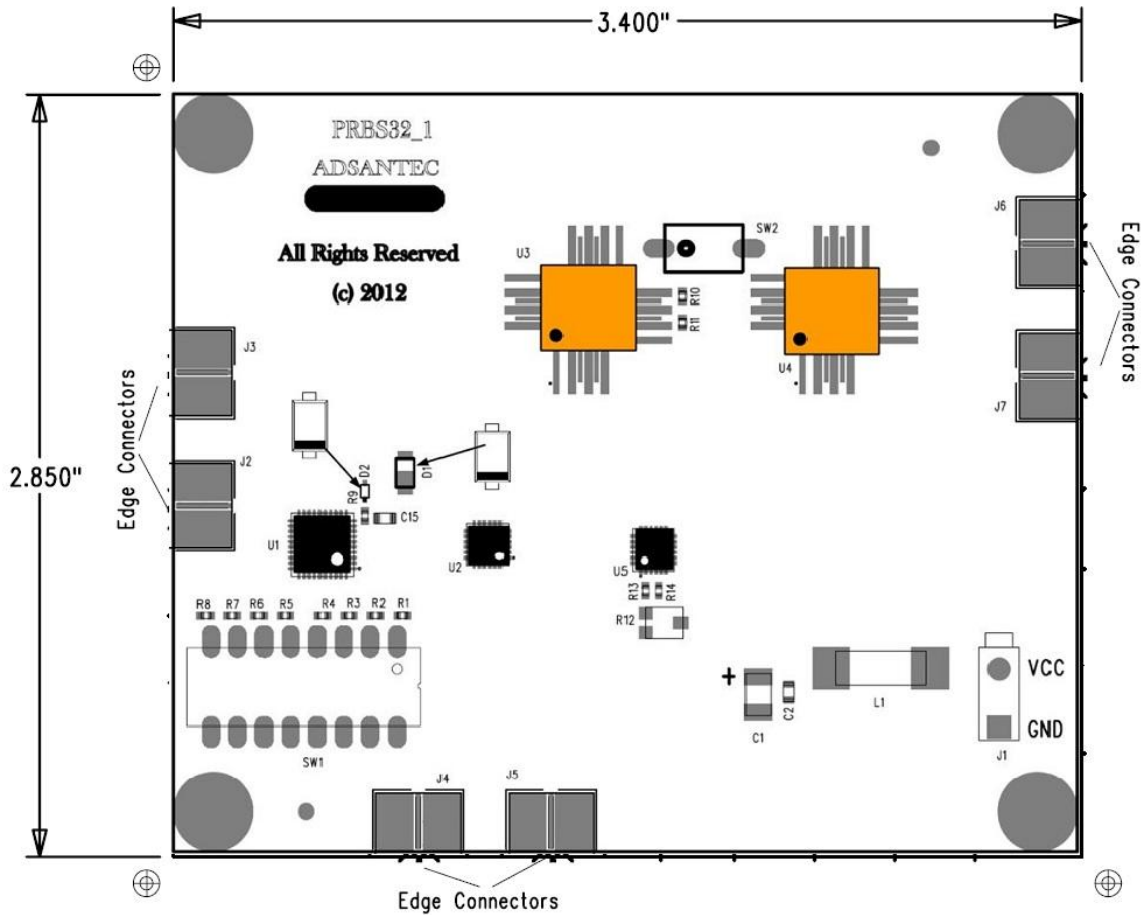

Fig. 12. Board dimensions diagram



REVISION HISTORY

Revision	Date	Changes
1.6.2	05-2023	Corrected Figure numbering Added Board Dimensions Section Added Fig. 12 Board Dimensions diagram
1.5.2	03-2022	Added Fig. 7. Recommended Board Configuration Diagram
1.4.2	06-2021	Updated for use with the ASNT8110-PQB divider Updated Electrical Characteristics section
1.3.2	07-2019	Updated Letterhead
1.3.1	04-2019	Added P/N of connectors to board description
1.2.1	06-2017	Revised Electrical Characteristics
1.1.1	04-2015	Updated pictures Added PRBS Select section Updated Operation section Revised Electrical Characteristics
1.0.1	04-2015	Initial release