

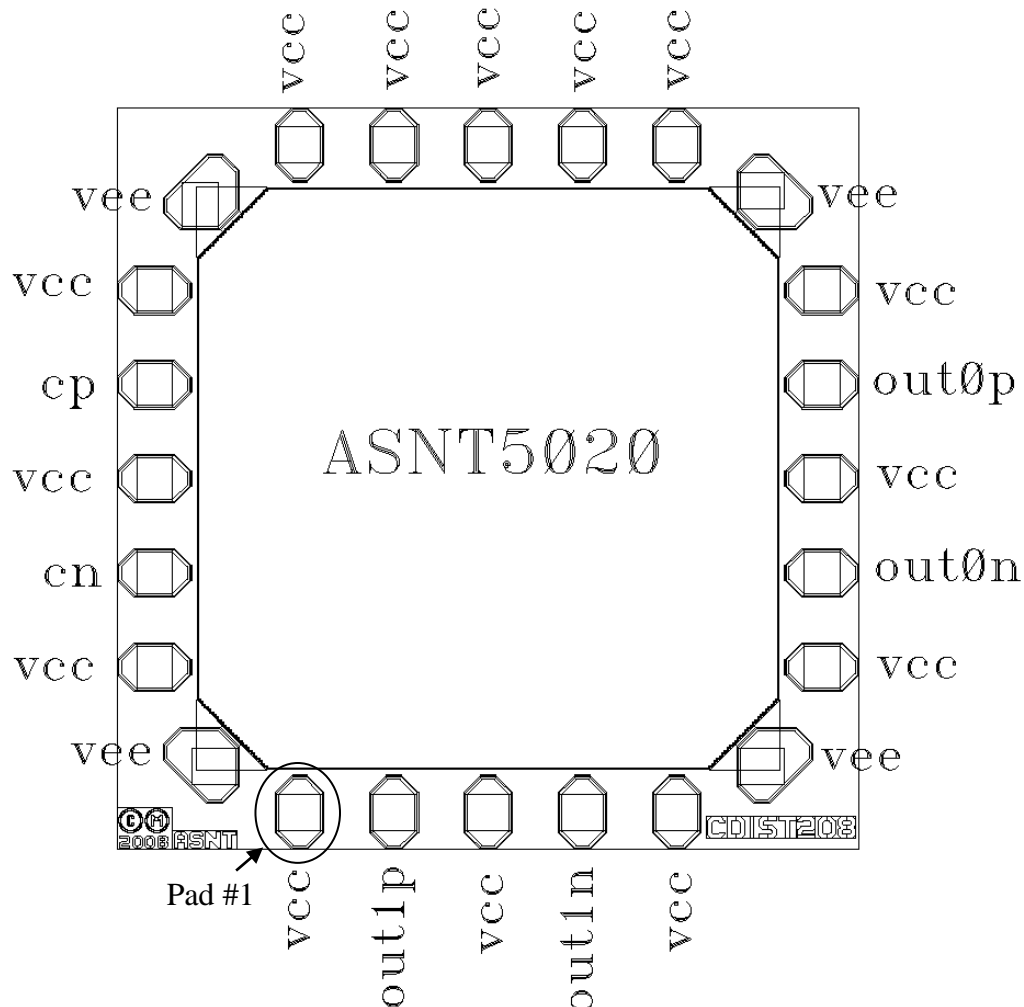

ASNT5020-BD DC-28Gbps/17GHz Signal Distributor 1-to-2

- High-speed broadband Data/Clock Amplifier and Distributor
- Exhibits low jitter and limited temperature variation over industrial temperature range
- One input differential signal port and two differential amplified output signal ports
- Matched phase delays for all outputs
- Fully differential CML input interface
- Fully differential CML output interfaces with 600mV single-ended swing
- Single +3.3V or -3.3V power supply
- Power consumption: 560mW
- Fabricated in SiGe for high performance, yield, and reliability





DESCRIPTION

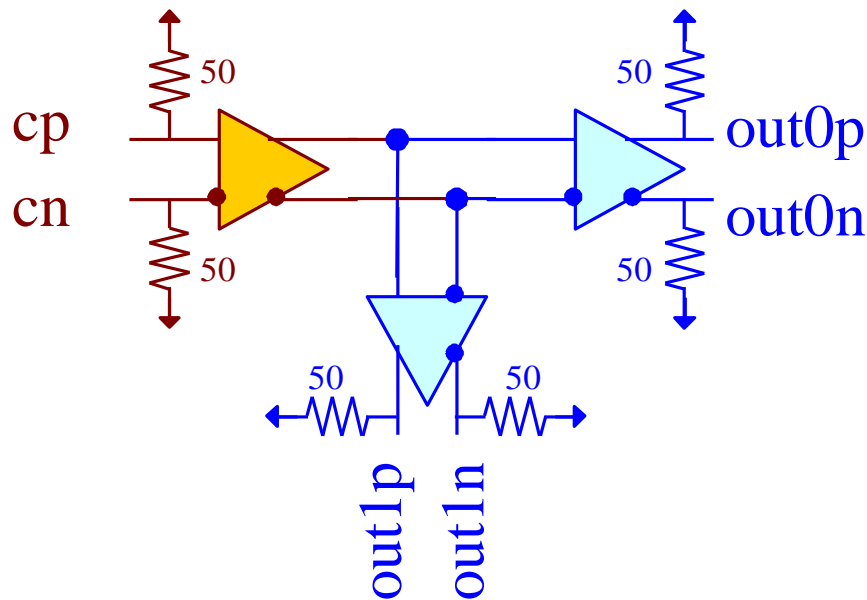

Fig. 1. Functional Block Diagram

The temperature stable ASNT5020-BD SiGe IC provides active broadband data/clock signal splitting, and is intended for use in high-speed measurement / test equipment. The IC shown in Fig. 1 can deliver two phase-matched copies of the broadband data/clock input signal cp/cn to two high-speed differential outputs out0p/out0n, out1p/out1n.

The part's I/O's support the CML logic interface with on chip 50 Ω termination to vcc and may be used differentially, AC/DC coupled, single-ended, or in any combination (see also POWER SUPPLY CONFIGURATION). In the DC-coupling mode, the input signal's common mode voltage should comply with the specifications shown in ELECTRICAL CHARACTERISTICS. In the AC-coupling mode, the input termination provides the required common mode voltage automatically. The differential DC signaling mode is recommended for optimal performance.

POWER SUPPLY CONFIGURATION

The part can operate with either negative supply (vcc = 0.0V = ground and vee = -3.3V), or positive supply (vcc = +3.3V and vee = 0.0V = ground). In case of the positive supply, all I/Os need AC termination when connected to any devices with 50 Ω termination to ground. Different PCB layouts will be needed for each different power supply combination.

The chip substrate should be connected to vee or completely isolated. DO NOT connect substrate to vcc!

All the characteristics detailed below assume vcc = 0.0V and vee = -3.3V.



ABSOLUTE MAXIMUM RATINGS

Caution: Exceeding the absolute maximum ratings shown in Table 1 may cause damage to this product and/or lead to reduced reliability. Functional performance is specified over the recommended operating conditions for power supply and temperature only. AC and DC device characteristics at or beyond the absolute maximum ratings are not assumed or implied. All min and max voltage limits are referenced to ground (assumed vcc).

Table 1. Absolute Maximum Ratings

Parameter	Min	Max	Units
Supply Voltage (vee)		-3.6	V
Power Consumption		0.62	W
RF Input Voltage Swing (SE)		1.0	V
Storage Temperature	-40	+100	°C
Operational Humidity	10	98	%
Storage Humidity	10	98	%

TERMINAL FUNCTIONS

TERMINAL			DESCRIPTION
Name	No.	Type	
High-Speed I/Os			
cp	20	CML input	Differential high speed data/clock inputs with internal SE 50Ohm termination to vcc
cn	22		
out0p	10	CML output	Differential high speed data/clock outputs with internal SE 50Ohm termination to vcc. Require external SE 50Ohm termination to vcc
out0n	8		
out1p	2	CML output	Differential high speed data/clock outputs with internal SE 50Ohm termination to vcc. Require external SE 50Ohm termination to vcc
out1n	4		
Supply and Termination Voltages			
Name	Description		Pin Number
vcc	Positive power supply (+3.3V or 0)		1, 3, 5, 7, 9, 11, 13, 14, 15, 16, 17, 19, 21, 23
vee	Negative power supply (0V or -3.3V)		6, 12, 18, 24



ELECTRICAL CHARACTERISTICS

PARAMETER	MIN	TYP	MAX	UNIT	COMMENTS
General Parameters					
vee	-3.1	-3.3	-3.5	V	±6%
vcc		0.0		V	External ground
Ivee		170		mA	
Power consumption		560		mW	
Junction temperature	-40	25	125	°C	
HS Input Data/Clock (cp/cn)					
Data Rate	DC		28	Gbps	
Frequency	DC		17	GHz	
Swing	0.05		1.0	V	Differential or SE, p-p
CM Voltage Level	vcc-0.8		vcc	V	Must match for both inputs
HS Output Data/Clock (out0p/out0n, out1p/out1n)					
Data Rate	DC		28	Gbps	
Frequency	DC		17	GHz	
Phase mismatch			2	ps	Between any two SE outputs
Logic "1" level		vcc		V	
Logic "0" level		vcc-0.6		V	With external 50Ohm DC termination
Rise/Fall times	13		17	ps	20%-80%
Additive Jitter			5	ps	Peak-to-peak
Duty cycle	45	50	55	%	For clock signal

DIE INFORMATION

The die has external dimensions of 1.18x1.18 μm^2 with an approximate thickness of 280 μm , and includes 24 octagonal pads: 5 on each side and 4 corner pads. The pad frame parameters are presented in Table 2.

Table 2. Pad Frame Parameters

Pad Type	Metal dimensions, μm	Opening dimensions, μm	Step, μm
Side pad	113x74	105x66	150
Corner pad	130x92	121x88	n/a

The part's identification name is ASNT5020-BD. The first 8 characters of the name before the dash identify the bare die including general circuit family, fabrication technology, specific circuit type, and part version while the 2 characters after the dash mark the part as a bare die.

This device complies with the Restriction of Hazardous Substances (RoHS) per 2011/65/EU for all ten substances.



REVISION HISTORY

Revision	Date	Changes
2.3.2	02-2020	Updated Die Information
2.2.2	07-2019	Updated Letterhead
2.2.1	04-2017	Added description of substrate connection Updated absolute maximum ratings section
2.1.1	03-2013	Added phase mismatch specifications Updated description
2.0.1	02-2013	Revised title Revised description Revised power supply configuration Revised absolute maximum ratings Revised terminal functions Revised electrical characteristics Changed package information to die information Format correction
1.1	05-2012	Corrected parameters
1.0	05-2012	Initial release