



ASNT28_1 DC-32GHz Clock Divide-by-4/1-to-512

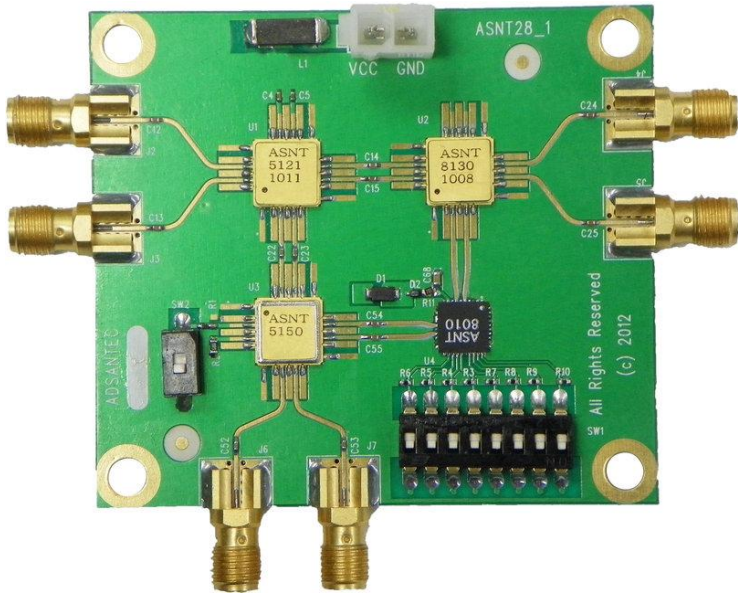

Fig. 1. ASNT28_1 evaluation board

- Broadband frequency range from 2KHz – 32GHz
- Minimal insertion jitter
- Fast Rise/Fall Times
- 50% duty cycle for all divide ratios
- Selectable divide output up to 512
- Selectable divide-by-1 output for buffering
- Second divide-by-4 output
- Single positive + 3.3V supply

Description

The ASNT28_1 divider is a multi-purpose divider for test, prototyping, microwave, and communication applications. There are two outputs, a fixed div/4 and a selectable 1-to-512 divide ratio. All inputs and outputs are AC coupled. The input waveform can be single-ended or differential. Emerson SMA connectors (MFG PN: 142-0761-881) are installed for inputs and outputs. The selectable divider output can be operated single-ended or differentially. Power is supplied through a two pin MOLEX connector (MFG P/N: 39-28-1023).

Applications

The ASNT28_1 divider can be used as a prescaler to extend the useful frequency range for triggering. The second fixed div/4 output can be used to synchronize other devices. The divider can be used in div/1 mode to buffer low amplitude signals or provide a differential output from a single-ended signal. The divider can be used as a prescaler for PLL's or frequency counters.

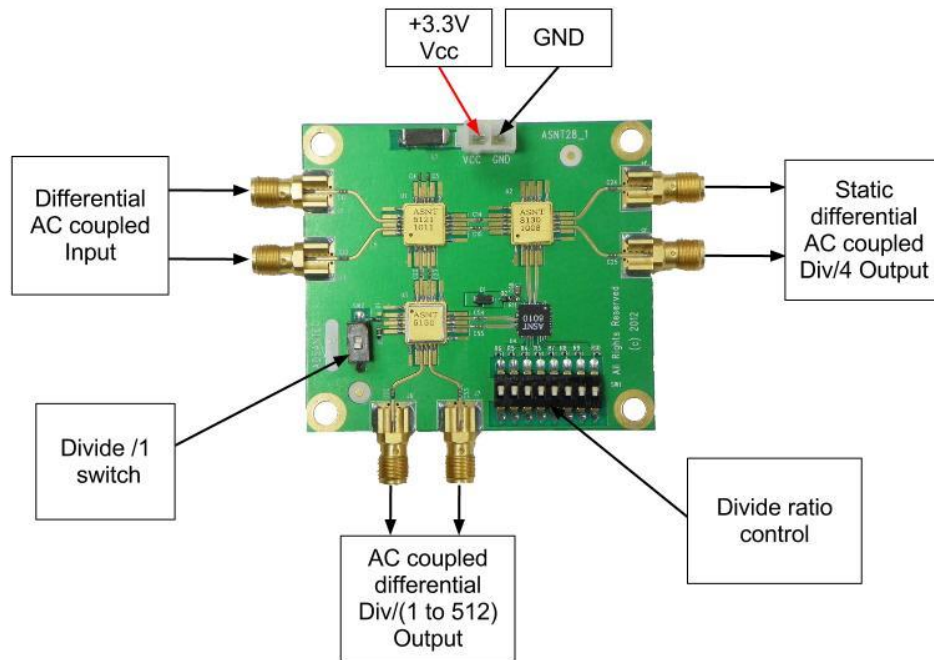

Fig. 2. Terminal Functions Diagram

Divide Ratio Control

The Div/(1 to 512) output can be configured to output any divide ratio from 1 to 512. All possible divide ratios are given by the following equation $\{\text{Div/output} = 2^n\}$, where n is an integer from 0 to 256. The Divide ratio control contains 8 switches which represent 8 bits. The LSB starts a SW8 and the MSB ends at SW1. The binary value of zero gives a decimal n value of 256. The binary value of 1, gives a decimal value n value of 1. Ascending binary values increases the decimal value n . Table 1 shows values of n .

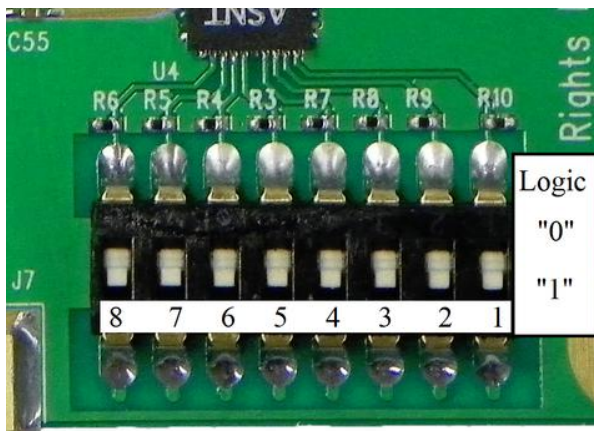

Fig. 3. DIP switch settings

Table 1.

DIP SW #	n
8 7 6 5 4 3 2 1	Divide Ratio
1 0 0 0 0 0 0 0	1
0 1 0 0 0 0 0 0	2
1 1 0 0 0 0 0 0	3
0 0 1 0 0 0 0 0	4
.	
.	
.	
.	
1 1 1 1 1 1 1 1	255
0 0 0 0 0 0 0 0	256



Divide /1 Switch

Switching the divide-by-1 switch to the off (div/1) position will override any divide ratio that is currently set on the divide ratio control and output a divide-by-1. Switching the div/1 switch to the on (div/2-512) position will turn on the divide ratio control.

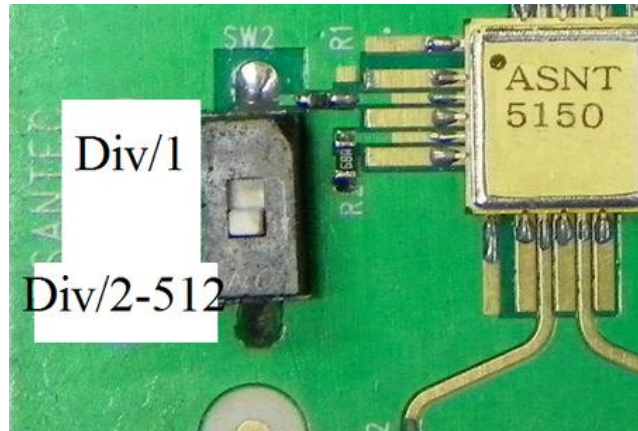

Fig. 4. Divide switch settings

Functional Block

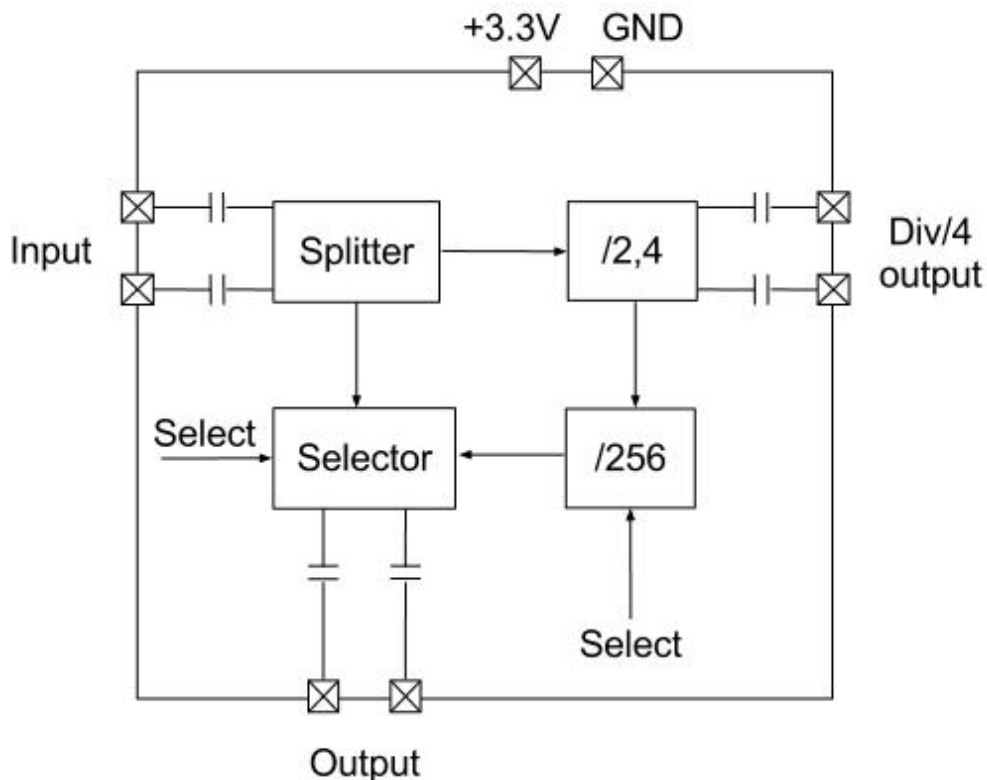

Fig. 5. Functional Block Diagram



Electrical Characteristics

Parameter	Min	Typ	Max	Unit	Comments
V_{EE}		0		V	External ground
V_{CC}	3.1	3.3	3.5	V	
I_{VCC}		1250		mA	
Power		3.3		W	
Operating Temperature	-25	50	85	°C	
Input					
Frequency	2.0E-6		32	GHz	
Single-ended Swing	50	400	1000	mV	Peak-to-Peak
Output (Div/4)					
Frequency	2.0E-6		8	GHz	
Single-ended Swing	380	400	420	mV	Peak-to-Peak
Rise/Fall Times	10	12	14	ps	20% to 80%
Additive Jitter		<1		ps	Peak-to-Peak
Duty Cycle	45%	50%	55%		For clock signal
Output (1 to 512)					
Frequency	2.0E-6		32	GHz	
Single-ended Swing	380	400	420	mV	Peak-to-Peak
Rise/Fall Times	10	12	14	ps	20% to 80%
Additive Jitter		<1		ps	Peak-to-Peak
Duty Cycle	45%	50%	55%		For clock signal



Board Dimensions

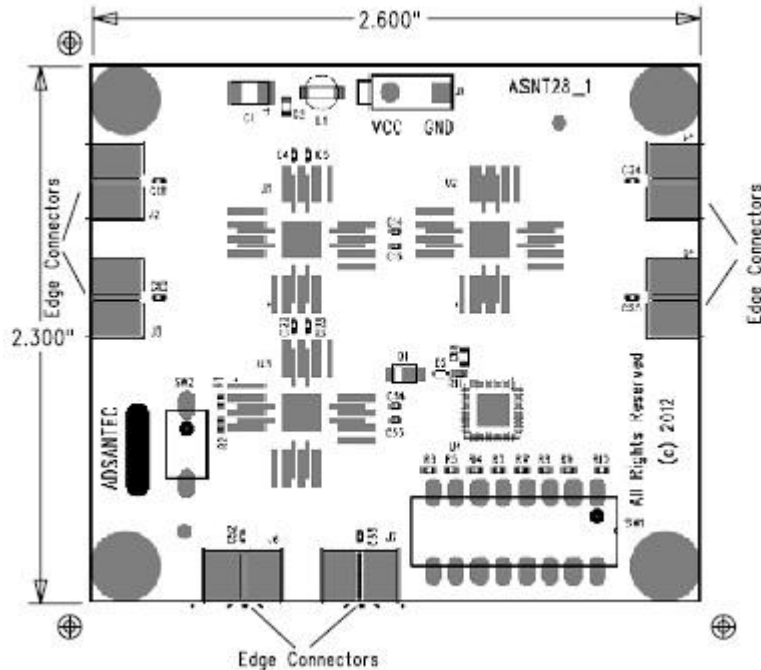

Fig. 6. Board dimensions diagram

Revision History

Revision	Date	Changes
1.7.2	05-2023	Updated Power Consumption Information Corrected Figure numbering Added Board Dimensions Section Added Board Dimensions diagram
1.6.2	06-2021	Updated for use with the ASNT8110-PQB Divider
1.5.2	07-2019	Updated Letterhead
1.5.1	04-2019	Added P/N of connectors to board description
1.4.1	08-2014	Updated Electrical Characteristics
1.3.1	05-2014	Updated Power Consumption Information
1.2.1	07-2012	Revised Formatting
1.2	06-2012	Document filename revised
1.1	04-2012	Modified Style Small corrections
1.0	02-2012	Initial Release